

RN4 TURBINE FLOWMETER

This flanged range of flowmeters will provide you with a highly accurate way of measuring liquids over the range of 2 to 9000 litres/min.

Highly accurate measurement of flow ✓

- Well proven
- Improve product quality
- Reduce costs and waste

Robust stainless steel construction ✓

- Corrosion resistant
- Very low maintenance and down time
- Withstands high temperature and pressure

High quality manufacture ✓

- ISO 9001 certified company
- Approvals for use in hazardous areas
- Individual calibration certificates

Low pressure drop ✓

Bi-directional flow capability ✓



Application

This range of flowmeters is used for liquids such as water, light oils, solvents and low viscosity chemicals. You can use them for batching, flow rate monitoring, controlling, blending and filling. The flowmeter is highly accurate and often used for testing the performance of pumps, engines, valves and other flowmeters.

In hazardous areas you can use the flowmeters with the Apollo IS pick-off coil approved to ATEX II 1 G EEx ia IIC T5. The signal can be used in the IS area or transmitted to the safe area using the intrinsically safe P5 preamplifier and suitable barriers.

Instrumentation

The signal can be used for a local display, remote display or converted for transmission to a separate control system. Apollo have a range of instruments to suit all your requirements.

Principle of Operation

When liquid flows and the rotor turns, the sensor detects the movement of the blade tips and generates pulses. The pulse frequency is proportional to the flowrate.

Construction

The stainless steel construction is durable and gives excellent corrosion resistance. The rotor is machined from solid making it virtually indestructible. The

sleeve bearings provide you with highly reliable performance over long periods.

Calibration

All Apollo RN4 turbine flowmeters are individually calibrated with water and are traceable to national standards.

We provide you with a test certificate for each meter showing the number of pulses per litre, which is used to set the instrumentation.

Installation

The flowmeter is installed directly into the pipeline. To reduce turbulence and get the best results from your flowmeter we recommend that you install it in a straight section of pipe with at least 10 pipe diameters upstream and 5 pipe diameters downstream.

Control valves should be installed downstream of the flowmeter.

To prevent foreign particles blocking your line we recommend you install a filter before the flowmeter. Preamplifiers are only needed if you have very long transmission distances or an electrically noisy environment close to pumps, motors, generators, switchgear or heavy current carrying cables. Intrinsically safe systems always require an IS pick-off coil. The IS P5 preamplifier is required for transmission to the safe area through barriers.

APOLLO

RN4 Turbine Flowmeter

Specification

Linearity:	Better than +/- 0.5% of reading
Repeatability:	+/-0.1% of reading
Pressure drop:	0.5 bar at maximum flow
Maximum overrange:	Up to 120% of the maximum flow rate for short durations
Maximum working pressure:	Subject to flange rating
Temperature range:	Standard pickoff -30°C to 110°C IS pick-off -30°C to 110°C High temp. -30°C to 232°C
Flanged connections:	ANSI 150, ANSI 300 DIN PN16,PN40 BS10 Table D ,Table E.

Materials of Construction

Body:	316 stainless steel
Sleeve bearings:	Up to 50mm - carbon graphite filled PTFE (max temp. 180°C) Optional tungsten carbide 80mm and above tungsten carbide (max Temp. 300°C)
Thrust balls/plate:	Tungsten carbide or ceramic
Rotor:	431 s/s or ferralium
Rotor shaft:	Tungsten carbide
Hangers:	316 stainless steel
Circlips:	316 stainless steel

Flowrate Ranges

Model Number	Flow Range litre/min	K factor# pulses/litre
RN4/20/5	5-50	1080
RN4/20/8	8-80	1080
RN4/25/15	15-150	620
RN4/25	25-250	362
RN4/32	45-450	250
RN4/40	67-670	70
RN4/50	110-1100	59
RN4/80	225-2250	14
RN4/100	450-4500	6.6
RN4/150	900-9000	2.3

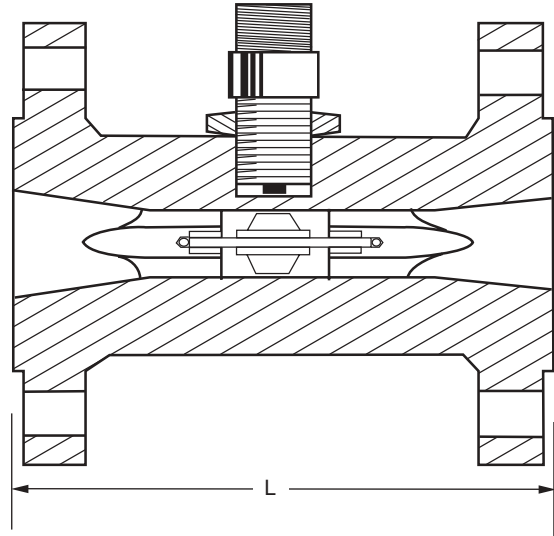

Dimensions

Model Number	Flange Size mm	L mm	Weight kg
RN4/20/5	20	139.7	2.0
RN4/20/8	20	139.7	2.0
RN4/25/15	25	139.7	2.2
RN4/25	25	139.7	2.7
RN4/32	32	145.0	3.9
RN4/40	40	152.4	6.5
RN4/50	50	165.1	8.4
RN4/80	80	250.0	14.5
RN4/100	100	300.0	16.5
RN4/150	150	360.0	16.5

The nominal K factor is based on water at 20°C
Each flowmeter is individually calibrated on water and will have a unique K factor.

Contact our flow measurement specialists for **FREE** advice on your application

Freefone 0800 328 6674

Freefax 0800 328 6673

e:mail sales@apolloflow.co.uk

website www.apolloflow.co.uk

The expert advice and the calls are **FREE**
So call now!

Apollo Flow Measurement Ltd, Charles Street, Walsall WS2 9LZ
Tel: 01922 645 647 Fax: 01922 640 326

APOLLO



ISO 9001 Cert. FM 31709